

Evaluating PC Technology for Enterprise & Industrial Settings:

Guidelines for Decision Making

**User
Requirements**

**User Physical
Environment**

Budgetary

Implementation

Network & OS

Maintenance

20 questions. That's the right number of questions an IT department should ask when determining whether all-in-one PCs make sense for your enterprise or industry. This white paper by Cybernet Manufacturing presents a checklist of considerations, and how to evaluate whether an all-in-one PC vendor measures up to these standards. IT managers, directors, CIOs and other IT staff will find this set of guidelines helpful for decision-making.

There are several key considerations when evaluating PCs for enterprise or industrial use listed here in the form of questions that should be asked. These factors are grouped into categories and include User Requirements (who will use the PC and how it will be used); User Physical Environment (workspace environment, mobility, environmental); Network (OS and connectivity); Implementation (resources, deployment issues); Maintenance (upgradeability, repair, warranty, tech support); and Budgetary (pricing, long-term planning). Any PC, whether it be an all-in-one for enterprise use or a more rugged computer for industrial use, should be evaluated against this checklist.

USER REQUIREMENTS

1. Application requirements: *What type of applications will be run on the system, and how much processing power do they require?*

Evaluate the number of applications that are in use simultaneously by each user, along with applications that may be graphics-intensive. (Individual users across the enterprise may have different requirements.) This will drive the amount

of RAM, size of CPU, and hard drive capacity that is needed for each PC. Most all-in-one PC vendors offer some choice of memory, CPU or hard drive, but some all-in-one PCs don't have upgradeable CPUs, memory or hard drives. Make sure that the all-in-one PCs you buy will handle both present and future requirements 3 to 5 years out.

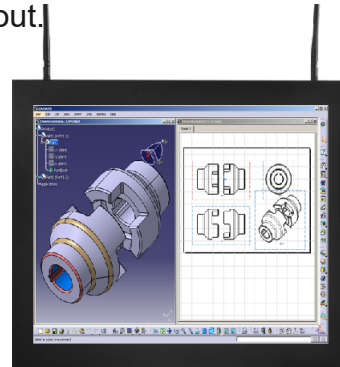

2. Reliability: *Is there a need to run the PCs 24/7?*

Every all-in-one PC vendor needs to have reliability data from internal tests or from an external source, and you should request it. A vendor may also have historical reliability data, expressed in terms of number of units shipped versus number of units returned for repair over time, along with some insight on root cause of the problems that required repair.

In addition to requesting reliability data, ask to speak with some of their customers who can provide anecdotal evidence of reliability. Make sure that your all-in-one PCs can handle continuous or near-continuous operation to meet the needs of your users. If your computer is an industrial PC, get real-world statistics on how rugged computers and tablets have fared against accidental damage and environmental hazards.

3. User interface requirements: *Do users need touch screen capability or other special interface technology?*

Users may need a touch screen interface on their PCs to use their enterprise software applications. When evaluating an all-in-one PC, you need to find out if touch screen capability is available now, or can be added to the unit in the future. Also evaluate vendors in terms of the type of touchscreen technology implemented. Capacitive technology is newer and more common currently than resistive, but some work environments such as a construction site require gloves which don't work well with capacitive screens. If your enterprise environment requires the use of gloves, make sure that the touch screen technology implemented will work with gloved touch. Touch screen PCs may also have multi-touch capability: 1-, 4-, 10-finger, etc. Make sure that you have the right touch screen technology as well as the most functionality for the money.

All-in-one PCs and industrial computers should have logically-located buttons or switches and easily identifiable markings to find them. An all-in-one LCD PC is also your monitor, so how does the user control display properties such as brightness and contrast, or control volume? All in one LCD PCs should have an on-screen display capability to give the user these measures of control.

4. Features, functionality, and expansion: *What type of ports, graphics, or multimedia does the PC have to support, and can you expand its capabilities?*

All-in-one PCs today must have a minimum set of features to support

Internet, graphics and multimedia, all of which are used in any business enterprise or industry today. A minimum of 4 USB ports should be available on the PC, along with a Gigabit Ethernet port. Users may even need two NIC ports; one for the Internet and one for an intranet. Along with standard features, it's extremely important to consider expansion capability.

Does the PC have expansion slots for serial or parallel ports, or perhaps a second NIC card? All-in-one PCs should be designed with the ability to add this capability and not be an enclosed system.

Some all-in-one PCs have an embedded graphics engine built into the motherboard chipset, or a dedicated graphics card with its own GPU and dedicated memory no less than 2 GB to handle complex graphics applications, including 3D renderings. Multimedia functionality needs to include high-res video and audio with Dolby Digital surround sound. Your users may have varying degrees of requirements for these features, so make sure that their current applications will work well with the targeted model, and check the Minimum HW Requirements for any new software application that you are thinking of purchasing over the next year. Consider that an industrial PC may be nearby loud equipment and machinery—if users need to enable audio, they need it strong enough to hear over equipment sounds.

5. Peripheral systems: *Are there any legacy I/O devices or equipment that the PC will need to interface with?*

Input devices such as readers and scanners are often used in both the enterprise and industrial environment—they often need to connect to a PC via

serial or parallel ports. If those devices will continue to be used in both the enterprise and industrial environment, then the all-in-one PC will need to have enough legacy port connections to support them. These connections are becoming increasingly more difficult to find in new PCs.



PHYSICAL ENVIRONMENT

6. *Workspace Environment: Where do you need to free up workspace now?*

Are there planned moves or construction that will change the users' workspace configuration? The current and future available workspace per user needs to be characterized at a high level. If there are remodels, moves or new construction planned for the users, you need to find out what the new configuration will be in order to plan the computer equipment for the space as well as the quantity of PCs needed. You need to consider whether there will be offices or cubicles, whether the desktop surface will be limited, how much floor space there is, and the location and access to cabling. The PC users need to be consulted as well. Where do they want to free up space or remove clutter? How can all-in-one PCs free up the workspace for your users?

For shared work areas such as reception desks, customer service counters, lab areas, or conference rooms, you need to identify the amount of space available on the desktop surface as well as floor space. For these areas, there may be limited floor

space, so all-in-one PCs in a monitor or keyboard will be essential and will reduce the amount of clutter when there is more than person using the PC equipment. What kind of materials will be around the PC? Will the PC be around biohazardous materials or excessive amounts of water? What kind of foot traffic or physical objects will be in range of the PC? These are considerations for different industries and what could possibly come in contact with the PC.

7. *Form factors: Which form factor best fits the workspace?*

Once you have an idea of how the user workspace is or will be configured, how much space do you have to work with? Will an all-in-one LCD PC or a different form factor be better for the space? If you're evaluating an all-in-one LCD PC, how wide a monitor can the space accommodate? You'll need to do some measurements of the space in order to choose the right dimensions of the PC, and to determine where the cable access points are.

There are two major form factors for all-in-one PCs which are pertinent to the screen aspect ratio: 16:9 and 4:3. Ensure that whatever workstations chosen will be able to accommodate the space required and the software's screen demands. Some software requires larger screens to be able to view all the necessary information without having to scroll. Other software only fits on a 4:3 screen ratio, so either the information provided will look stretched, or not all of the screen real estate will be used.

Is the workspace a warehouse requiring mobility? If so, would an industrial tablet

be a better solution? Consider what employees are comfortable with carrying around as well as battery life constraints.

8. Environmental requirements:

Depending on how the PC will be used and the environment in which it will be used, what special features/specifications are required?

All-in-one PCs are designed using components that should require less power, and therefore save energy. Look for an Energy Star 6.1 rating. The Energy Star designation is an energy efficiency guideline set by the U.S. EPA and U.S. DOE. By purchasing Energy Star qualified products, businesses can save up to hundreds of thousands of dollars annually.

Some environments also require a fanless PC that reduces the amount of circulating dust or particulate matter in the air; look for all-in-one PCs or rugged industrial computers that utilize fanless cooling technology. Fanless PCs are great for sterile environments in medical facilities, and also for factories with clean rooms. Also, some industrial environments may have extreme temperature climates, so the build quality is an important factor. In some manufacturing environments that produce dust or dirt, a fanless PC is desirable because this debris won't be sucked into the computer. Keeping dust out of the PC will extend its lifecycle.

Some all-in-one PC manufacturers also have "green" policies for take-back recycling and using recyclable materials; you should check the vendor's websites for those specifications and their products' green ratings. The EPEAT rating is especially important in reducing the environmental impact of electronics

products. EPEAT is a program of the Green Electronics Council, a government and industry consortium that developed a set of 51 criteria to achieve different ratings: Bronze, Silver, or Gold. The higher the EPEAT rating, the better.

9. Hardware mobility/Mounting options:

Will the PC need to operate on a mobile cart, or will it need to be mounted on a wall or extension arm?



Server-grade computers are often mounted within horizontal racks, while DIN-mounted computers sit together on a rail. All-in-one PCs may need to be mounted on a VESA mount, either 75mm or 100mm in order to free the workspace up from clutter.

Another consideration for all-in-one PCs that will be used on a cart is the type of software applications that will be used on a cart. Most of these applications are server-side and therefore don't require a lot of processing power or memory. That means that the processing power of the all-in-one PC levels doesn't have to be high-end, so that will save you some money. For example, a PC with an Intel H270 chipset and 4-8 GB of RAM will be adequate for these types of software applications. If the all-in-one PC will be on a cart, you will definitely need adequate wireless capability to connect with the required networks. In addition to the usual 802.11 a/b/g/n standards, you

will need 802.11 “ac”, which is 5Ghz. Make sure that the all-in-one PC can support this connectivity. If the PC will be placed on a wall, make sure the PC hardware has standard 75/100mm VESA mounting holes without requiring special adapters that may add to the purchase price.

NETWORK & OS

10. Operating system requirements:

Which operating system does the enterprise use now, and will it be changing in the next year?



Some enterprises are still using Windows 7 and have not yet transitioned to Windows 10. If your enterprise software is not compatible with Windows 7, that can be a huge expenditure to invest in software upgrades. Therefore, if you’re not ready to upgrade software, you should find PC hardware that will support backward compatibility to Windows 7. No matter which all-in-one PC you buy, make sure that loading Windows 7 on it won’t void the warranty. All-in-one PCs deployed throughout the enterprise may require a special administrative control/access interface that sits in front of the Windows desktop. If that needs to be installed on all PCs, make sure this is something that the all-in-one PC vendor can do if you have them provide an imaging service.

11. Network requirements: *What are the technical requirements for internal and external networks, and security?*

Network connectivity is crucial for all enterprise and industrial PCs, so it’s of utmost importance that PC hardware also support network security systems and software. You’ll need to consider the types of connectivity the all-in-one PC can support – both wired and wireless. For wired connections, the all-in-one PC should have at least one Gb Ethernet NIC and preferably two of them because in some enterprise and industrial environments, a second NIC may be needed to control another device that receives or collects data. If the all-in-one PC only has one Gb Ethernet NIC, find out whether another one can be added. The evolving standards for wireless networking and security also factor into your assessment of an all-in-one PC. Many enterprises use Cisco networks with CCX authentication as part of the infrastructure, so make sure wireless devices supported by your all-in-one PC will be compatible with the full range of 802.11 a/b/g/n standards. The 802.11 “ac” is a new standard required in some enterprise environments such as hospitals; 802.11ac devices operate at a 5GHz frequency and therefore don’t interfere with other wireless devices that may be locally in use.

IMPLEMENTATION

12. IT resources available: *How large a staff do you have now and over the next year for HW implementation and maintenance?*

If you have limited staff, it’s a good idea to

decide how many manufacturers you can feasibly work with at one time. For a given project, procuring all-in-one PCs from multiple manufacturers will take a lot of time because support will be different for each one. If you standardize on one manufacturer's platform, you can push upgrades out simultaneously, support it more easily, and serve your users more effectively.

13. Conversion challenges: Which hardware and software will have to be converted to the all-in-one PCs?

One of the advantages of all-in-one PCs should be ease of deployment, so evaluate a demo model to find out how simple it is to connect the PC to power and the network. It should take only a few minutes to connect and install the hardware. The other consideration is operating system and enterprise software. It will save you a lot of time and money to find an all-in-one PC manufacturer that offer imaging/ghosting services that make it easier to do system-wide roll-out and implementation.

Tier 1 all-in-one PC manufacturers such as HP, Dell, or Lenovo don't offer such services, but Tier 2 manufacturers do offer imaging. The process is simple: the manufacturer ships you one unit, you add your software and configure it and ship it back to the manufacturer, who then images the remaining units. When you receive the shipment of PCs, you're ready to go. Imaging services reduce deployment time by several days.

MAINTENANCE

14. Upgradeability: Can the targeted all-in-one PC be upgraded? What is the

upgradeability of the targeted all-in-one PC?

Some all-in-one PCs are closed systems and the warranty is voided if hardware is opened up to add more memory modules or change out a CPU. The other factor to evaluate is whether you can adapt the PC to future needs, such as adding a touch screen or other functionality a year or two out. Also find out whether there are expansion slots inside the PC – another good way to add features and functionality in the future. Expansion slots should be PCI express or mini-PCI Express. The older 32-bit PCI card slot is too old, and you won't be able to find cards for it (although some PC manufacturers still offer them, so be on the lookout.) When it comes to PC hardware, if you have the ability to upgrade, you extend the product lifecycle and save money.



15. Access for Repair: Can the targeted all-in-one PC be opened? Do you have access to the inside of the PC to do repair?

If it's an enclosed system, you may have to return it in order to do a repair; that results in downtime for one of your users. Sometimes the PC warranty prohibits the user from opening up the PC without voiding the warranty. If you have the technical resources to do troubleshooting and simple repair in-house, having easy access to the inside of the PC is an important consideration. Along with the ability to access your PC for repair, it's also essential that

the manufacturer is willing and able to send you the spare parts that you can replace yourself. With all-in-one PCs, the motherboards are usually custom-designed, but you should be able to replace the CPU, hard drive and memory with off-the-shelf or manufacturers' parts. Beware of PCs that have the memory modules soldered on to the motherboard; manufacturers do this to reduce the physical profile, but that means you can never change out the memory.

16. Warranty: *What types of warranties are available and what are the terms?*

PC standard warranties are fairly uniform throughout the industry; usually one year parts and labor. You should also find out whether extended warranties are available, and evaluate the price of them versus the price of the PC. All-in-one PC manufacturers should offer extended warranties up to 4 or 5 years, because most enterprises and industries keep PCs that long and you want to have warranty protection for their entire lifecycle. For both standard and extended warranties, read the fine print to learn what voids a warranty or not; are your normal maintenance practices compatible with the terms of the warranty?

17. Tech support: *What are the details of the Tech Support offered by the manufacturer?*



Cybernet Headquarters is located in Irvine California, and is home to our sales and technical support staff.

Tech support is always a crucial issue for PC hardware, and there are several things to consider. The first is location of the manufacturer's tech support operations. U.S.-based support is advisable, especially for U.S. companies. Assess the level of knowledge that the manufacturer's tech support staff has. Are they employees of the manufacturer who know the technology and have repaired the PCs themselves? That's the most desirable type of tech support.

The alternative is a situation where tech support is outsourced and workers just follow a script or workflow diagram. These call centers are often located overseas and present language barriers and bad phone connections. On top of that, outsourced/offshore call centers often handle support for many manufacturers at one time, and therefore are not company employees, and don't have the same level of technical knowledge. Which type of tech support would you rather have for your mission-critical operations? You should demand dedicated tech support to get all the levels of support you need from one manufacturer. Also ask them what types of support are offered: phone, email, or chat.

Inquire as to how the manufacturer handles returns, and who pays for shipping. The manufacturer should pay for shipping both ways for returns. Manufacturers should also offer a 30-day return policy. Find out where the service centers are when you ship something back; if you're in the U.S., you don't want to ship your unit to Asia for repair, which can take months to get the unit back to you. Warranty repair services are usually available, and manufacturers may also offer out-of-warranty repair for a flat fee, or hourly fee. Do some research on these

services to see if the range of services will be a good fit for your IT operations.

BUDGETARY

18. Pricing: *What is the price of the all-in-one PC, and will it fit our budget?*

There are a lot of all-in-one PCs out there to choose from, with prices ranging from \$499 to more than \$2000. You need to consider features/functionality needs now and expansion in the future. It's always wise to budget for tomorrow (3 years from now), not for today. Make sure you have upgrade paths for your all-in-one PCs to get the most out of your investment.

19. Manufacturer Verification: *Is your targeted all-in-one PC vendor the real manufacturer of the PC?*

There are many companies in the PC industry that claim to be the real original equipment manufacturer (OEM), but are really resellers of a PC manufacturer's products instead. These resellers may put their own brands or labels on the equipment, but it is manufactured by some other company that is often located overseas.

Unless you are dealing with a large Tier 1 vendor like HP, Dell, Lenovo, etc., you should take steps to verify that the vendor's products meet the electronics standards expected of all PCs today. OEMs should make available their FCC, CE and UL certification and documentation; any one of these certifications will be about 150 pages in length. If the vendor is not willing to make this documentation available to you, then they are likely not the manufacturer.

What's the downside of not using an OEM for your all-in-one PCs? Tech support, warranty, upgradeability, and continuing product lifecycle will likely be less than adequate if you are not dealing with an OEM, which can cost you time and money in the long run. It pays to do your homework when you are selecting an all-in-one PC vendor.

20. Product lifecycle: *How long will we need to keep these all-in-one PCs before replacing them?*

Companies are keeping PCs for longer periods of operation time than previously. Will the all-in-one PC that you are considering last longer for your needs? Does the manufacturer have product line continuity into the future so that they will remain in business, offer new products to upgrade to, and future support?

Vendors' product lifecycles should be compatible with your IT lifecycle needs. On the one hand, it's good to be able to have a new PC model with updated features and functionality when you are ready for it. On the other hand, some all-in-one PC manufacturers have very short product lifecycles and release new product models too frequently; some as often as every two months. It's better to find an all-in-one PC manufacturer that has a different product cycle – one with longer intervals between releases. You need to be aware of your own company's PC lifecycle, and how long the PC configuration has to stay the same hardware-wise and also software-wise. You don't want to have to re-image your systems every few months, either. Choose a manufacturer based on their ability to provide the all-in-one PC technology that will fit your company's product lifecycle.

ABOUT CYBERNET

Cybernet Manufacturing is a global manufacturer of all-in-one PCs and tablets built with military grade components to ensure durability and reliability. Cybernet serves a variety of vertical markets such as health care, industrial, business, banking, and education.

Cybernet is privately held, and is headquartered in Irvine, CA, with operations in Taiwan, China, and Europe. The company employs 450+ employees worldwide.

Corporate Headquarters

Cybernet Manufacturing
5 Holland
Irvine, California 92618
Free: (888) 834-4577
Phone: (949) 600-8000
Fax: (949) 600-8013
www.cybernet.us
sales@cybernet.us

UK & European Inquiries

Cybernet Europe
Network House, Hawkins Road
Colchester, Essex CO2 8LA
United Kingdom
Phone: +44.0845.539.1200
Fax: +44.0845.539.1201
www.cyberneteuropa.com
sales@cyberneteuropa.com

Asia & Middle East Inquiries

Cybernet Asia Co., Ltd.
No.25, Lane 140, Xingai Rd
Neihu District, Taipei City
11494,
Taiwan (R.O.C.)
Phone: (02) 2790-4776
Fax: (02) 2793-3172
www.cybernet.com.tw
sales@cybernet.com.tw

